

SolarMax S-Serie

2000S / 3000S / 4200S / 6000S

Gerätedokumentation ■ Instruction manual ■ Documentation d'appareil
■ Documentación del dispositivo ■ Documentazione dell'apparecchio



 SWISS QUALITY

 **SolarMax**[®]
by Sputnik Engineering



Headquarters of Sputnik Engineering AG in the former Rolex building in Biel, the Swiss watch metropolis.



SolarMax string inverter: powerful, reliable, innovative.

Introduction

Thank you for choosing a SolarMax solar inverter!

SolarMax converts the direct current from your solar system into grid-compliant alternating current.

As a solar system operator you expect reliability and high yield from your system. With our SolarMax range we offer inverters that fully meet these requirements. The SolarMax inverter range is characterised by high efficiency and high availability.

The inverters carry the CE mark as an indication of compliance with European Union Directives.

The "Type Approved" quality mark from TÜV Rheinland confirms compliance with all relevant safety standards.

Ch. von Boge *Ph. Muth*

The Management

Sputnik Engineering AG
Höheweg 85
CH-2502 Biel/Bienne

E-Mail: sputnik@solarmax.com

Contents

	Introduction	54			
1	Safety instructions	57	5	Troubleshooting	86
			5.1	Introduction	86
			5.2	Troubleshooting via the graphics display	87
			5.3	Maintenance	90
2	Installation	58	6	Data communication	91
	2.1 Installation	58			
	2.2 Electrical connection	61	7	Disposal	93
	2.3 Overvoltage protection	64			
	2.4 Switching on and off	65	8	Technical description	93
	2.5 Removal	65	8.1	Technical configuration SolarMax 2000S/3000S	93
	2.6 Configurable limit values and operational settings	66	8.2	Technical configuration SolarMax 4200S/6000S	93
	2.7 Heat sink temperature limit	67	8.3	Safety functions	94
	2.8 Initial setup	67	8.4	Control functions	94
	2.9 Status signalling contact	68	8.5	Technical data SolarMax 2000S/3000S	95
3	Auto Test	70	8.6	Technical data SolarMax 4200S/6000S	96
	3.1 Auto Test definition according to DK 5940 (Italy)	70	8.7	Glossary	97
	3.2 Start Auto Test	70	8.8	Efficiency	98
	3.3 Procedure	71	9	Warranty	100
4	Operation and fault display	73	9.1	Warranty	100
	4.1 Graphics display	73	9.2	Prolongation of guarantee	101
	4.2 LED display	73	9.3	Limitation of liability and warranty	101
	4.3 Menu key symbols	74	9.4	Applicable law	101
	4.4 Menu structure	75	9.5	Place of jurisdiction	101
	4.5 Communication activity	82			
	4.6 Status messages	83			
	4.7 Alarm signals	85			

1 Safety instructions



- SolarMax inverters may be installed only by qualified electricians.
- Please do not commission the device if the casing is damaged or you are not sure whether the device is working properly! Immediately disconnect the device from the mains and from the solar generator!
- Before opening the SolarMax device, the DC and AC feed lines must be disconnected.

- Large arcs may be generated if connectors are disconnected on the DC side during operation. The DC cable must therefore be disconnected before removing the MC connectors by means of the DC insulation switch on the left-hand side of the inverter.
- Caution: The discharge duration of the capacitors is 5 minutes.
- Please follow the detailed installation instructions in Section 2.
- Failure to observe the installation instructions will void any warranty and liability.
- Disconnect your SolarMax inverter from the mains by disconnecting the AC feed line before carrying out any maintenance and cleaning on the solar generator.
- Please follow the general local installation regulations.

2 Installation



SolarMax inverters operate with high DC voltages. The complete system must therefore be installed with great diligence, following all relevant regulations. Contact with live parts can cause critical injuries or death. Only suitably qualified personnel may connect the SolarMax inverter to the mains. The installer must be approved by the relevant energy utility company.

The maximum solar generator output can be found in the data sheet.

Warning: The device may only be opened in de-energised state (AC and DC side). Wait for 5 minutes to allow the capacitors to discharge.

en

2.1 Installation

The device should be installed and connected with the cover closed. Sputnik Engineering has developed a mounting rail in order to simplify the installation. Two zinc-plated wall screws (6 x 50 mm) and two wall plugs are included. First install the mounting rail on the wall. The SolarMax inverter can then be pushed onto the mounting rail. Fasten the inverter at the left and right of the mounting rail with two M6 x 12 screws.

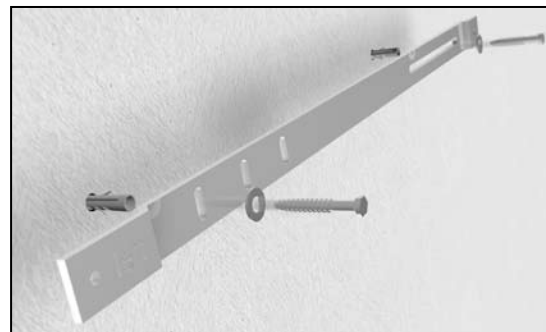

58

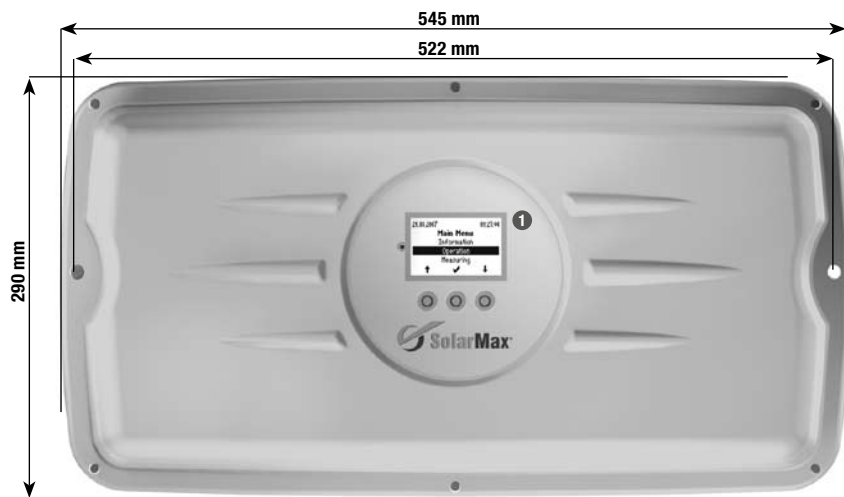

- ① Graphics display with operation
- ② AC connector
- ③ DC connector
- ④ DC insulation switch
- ⑤ Status signalling contact

The SolarMax housing meets the requirements of protection type IP54 and is suitable for outdoor installation. Protection rating IP54 is only met if the enclosed AC connector and the solar generator are connected via the MC4 connectors.

In order to maximise the energy yield it is important to position the inverter correctly. The lower the ambient temperature, the more efficiently the inverter will operate.

Notwithstanding the high efficiency of the SolarMax inverter, approx. 5 % of the power has to be dissipated in the form of heat. To this end the base of the device is made from cast aluminium, which ensures adequate cooling via convection and an additional fan.

Please note:

- The SolarMax may only be operated in an overvoltage category II AC installation! If this is not the case, additional overvoltage-limiting elements (varistors) must be installed at the network connection point.
- If the SolarMax device is installed inside a building, the space should be well ventilated.
- The inverter must be mounted on a solid surface.
- For flammable surfaces an additional fireproof panel must be used, since the heat sink may reach temperatures of up to 80 °C.
- Please refer to the technical data for the maximum permissible ambient temperature.
- For optimum cooling the following distances should be adhered to: 0.5 m above, 0.5 m below, 0.5 m at the sides.
- Multiple devices should be installed above each other, if possible. For side-by-side installation the minimum distance between devices should be 0.5 m. If different SolarMax models are installed, the following sequence must be adhered to from left to right: SolarMax 2000S, SolarMax 3000S, SolarMax 4200S, SolarMax 6000S.
- In external installations direct sunlight should be avoided. A protected installation location, for example under a canopy or a solar module, would be an advantage. The device should also be protected from splashing, for example rainwater dripping off roof or module edges.
- The inverters must not be installed in cabinets, enclosed recesses or similar locations.
- Do not store flammable liquids near the inverter. Do not subject the inverter to flammable gases or vapours.
- The inverter must be positioned out of reach of small children.
- The inverter and the supply lines must be installed such that they are inaccessible to pets (especially rodents).
- Due to noise emission it is advisable to avoid installation in living areas.

2.2 Electrical connection

Sputnik Engineering supplies the SolarMax inverters prewired and ready for connection. All connections are pluggable. The device therefore does not have to be opened.

The following connections are available:

- DC: 3 x 2 MC4 sockets (3 strings with MC4 connectors)
- AC: Wieland flange connector
- Communication: 2 x RJ45 (sealed with protective caps)
- Status signalling contact M12 connector

SM2000S/3000S/4200S/6000S



3 x 2 pairs of MC4 connectors
DC feed line

Status signalling contact

Wieland flange connector
AC feed line

2 x RJ45 sockets
Data communication

If the RJ45 sockets are used and the inverter is exposed to the weather, please use products from the VARIOSUB-RJ45 range with IP67 protection from Phoenix Contact. This ensures that the installation meets the requirements of IP54.

- RJ45 connector, 8-pin, quick connector system (art. no. 1658493)
- Pre-assembled Ethernet cable, 8-pin RJ45/IP67 on RJ45/IP67 (art. no. 1658480-)

Available from www.phoenixcontact.com.

Assembly of the AC cable socket

SM2000S/3000S/4200S/6000S:

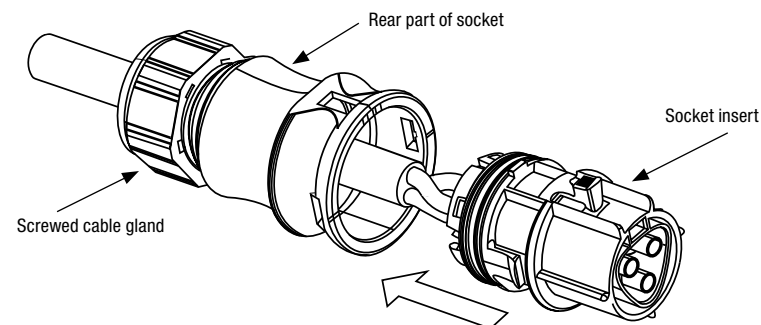

Ensure that the cable is de-energised.

- Connect the AC cable socket with a flexible cable according to EN60309-2 / VDE 0623. Strands with a max. cross-section of 4 mm² can be connected.
- Push the rear part of the socket over the cable.
- Press wire end sleeves onto the stripped strands.
- Connect the individual wires with the insert in turn as follows (Strand cross-section: see table on page 63).
 - Protective earth conductor PE with the screw terminal with earthing symbol
 - Neutral conductor N on screw terminal with the label N
 - Phase L on screw terminal with the label L
 - Tightening torque 0.8 – 1.0 Nm
- Ensure that the wires are connected properly.
- Snap the rear part of the socket onto the socket insert.
- Tighten the screwed cable gland.

Back-up fuses and cable cross-sections

Follow the generally accepted state of the art. Start on the AC side.

AC side:

Each inverter must be protected separately! No consumers may be connected between the fuse and the inverter!

Type	2000S	3000S	4200S	6000S
Back-up fuse (characteristic C)	10 A	13 A	20 A	25 A
Minimum cable cross-section (strand)	1.5 mm ²	1.5 mm ²	2.5 mm ²	2.5 mm ²

We recommend using larger conductor cross-sections in order to minimise line losses. The flexible cable is connected to a junction box with a maximum length of one metre. From here the installation may be continued with a rigid TT cable.

DC side:

Select the cable cross-sections on the DC side to suit your system configuration and in accordance with the relevant installation regulations.

General information:

- When connecting several SolarMax devices, distribute the inverters over the three mains phases.
- AC and DC cables must be suitable for the expected loads, currents and ambient conditions (temperature, UV, etc.).
- The personal protection regulations must be followed when the inverter is connected to the AC system.
- Ensure that the mains cable is de-energised before connecting the device.
- Before installing the DC side, check the polarity once more.
- Ensure short circuit- and earth-leakage-proof connection of the DC cables to the MC terminals.
- Caution: Due to the earth-fault monitoring function, neither the minus nor the plus terminal should be earthed. Otherwise the integrated insulation monitoring function would prevent grid feeding.
- Connect the DC side via the MC connectors.



Large arcs may be generated if connectors are disconnected on the DC or the AC side during operation. The AC supply and the DC insulation switch must therefore be disconnected before removing the connectors.

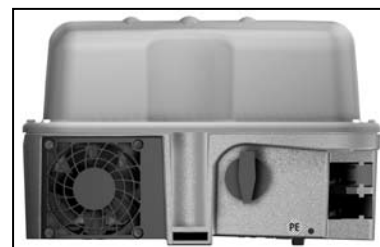

Earthing (second protective earth connection)

The inverter's stray current to earth can reach values greater than 3.5 mA (AC) or 10 mA (DC) during operation. In this case, a second secure protective earth connection is required according to EN 50178. The cross-section of the second protective earth conductor should have at least the same cross-section as that of the main terminal. A second protective earth conductor can be connected below the status signalling contact.

2.3 Overvoltage protection

SolarMax inverters feature integrated surge protectors at the input and output. On the DC side 2 surge arresters (varistors) for the plus and minus terminal to earth are installed. On the AC side a surge arrester (varistor) is installed between the phase and neutral. All surge arresters meet the requirements of class D according to VDE 0675-6 or Type 3 according to EN 61643-11.

Note the following if the overvoltage protection on the DC is to be increased:

- For inverters without galvanic isolation the DC terminals have a potential relative to earth that may be higher than the peak value of the mains voltage. For this reason, the response voltage of the surge arrester must be higher than 600 V_{peak}.

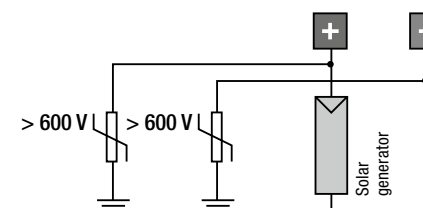

The diagram on the left shows the connection of additional surge arresters on the DC side.

2.4 Switching on and off

- All SolarMax inverters operate fully automatically and maintenance-free. The isolating switches between the solar generator, the inverter and the 230 V mains supply remain on at all times. SolarMax will start and transfer power to the 230 V grid when the irradiance is high enough. Otherwise the device remains in stand-by mode and is thus available for grid feeding at all times. Overnight the electronic system is disconnected from the mains.



Voltage may only be applied on the DC and AC side of the SolarMax with the device closed.

Switching on:

- Switch on DC insulation switch.
 - The graphics display powers up.
 - During the night or at times of insufficient irradiance the graphics display turns itself off (no energy consumption).
- Switch on the AC isolating switch (may be fused).

Switching off:

- Switch off the AC insulation switch.



Large arcs may be generated if connectors are disconnected on the DC side during operation.

- Switch off the DC insulation switch.

2.5 Removal

- The device does **not** have to be opened for demounting.
- The inverter must be de-energised. **First disconnect the device from the mains on the AC side via the AC line protection breaker or the fuse.** Then open the DC insulation switch in order to disconnect the inverter from the solar generator field. Now remove the connectors.
- Before releasing the screws ensure that the bottom of the device (heat sink) has cooled sufficiently to allow the device to be safely handled.
- Release the two locking screws on the left and right and remove the inverter from the mounting.

2.6 Configurable limit values and operational settings

In the SolarMax S series the following parameters can be set manually via the interface with the MaxTalk software. The settings are password-protected. A password application form can be ordered via the SolarMax hotline. The password is only made available to installers who sign the form. The password is not made available to private individuals or system operators.

Parameter	Unit	Regional settings						Password-protected setting
		DE/CH	IT	ES	FR	GR	Other	
Vac max	V	264	274	253	264	264	300	184...300
Vac min	V	184	186	196	196	184	184	
f max	Hz	50.2	50.3	51	50.5	50.5	55	45...55
f min	Hz	47.5	49.7	49	49.5	49.5	45	
df/dt max	Hz/s	NA	0 (Inactive)	NA	NA	NA	NA	0.1...1
Vac 10min max	V	253	0 (Inactive)		264	0 (Inactive)		243...264
Ierr max	mA	300	300	300	300	300	300	50...300
Iac mean max	A	1	0.5 % of Iac rated*	1	1	0.5% of Iac rated*		0.05...1
Restart delay	s	0	0	180	0	180	0	0...600
Pac max SM2000S	W	1980	1980	1980	1980	1980	1980	990...1980
Pac max SM3000S	W	2750	2750	2750	2750	2750	2750	1375...2750
Pac max SM4200S	W	4180	4180	4180	4180	4180	4180	2090...4180
Pac max SM6000S	W	5060	5060	5060	5060	5060	5060	2530...5060
Iac max SM2000S	A	12	12	12	12	12	12	6...12
Iac max SM3000S	A	12	12	12	12	12	12	6...12
Iac max SM4200S	A	19	19	19	19	19	19	9...19
Iac max SM6000S	A	22	22	22	22	12	22	11...22

NA: not available

* Iac max = 1.1 x Iac rated

The currently set values can be retrieved via the display in the main menu under Configuration (see section 4.4).

2.7 Heat sink temperature limit

For safety reasons the temperature of the heat sink is limited to 80 °C. At ambient temperatures of more than 45 °C the heat sink temperature may reach 75 °C. In this event the maximum inverter output is reduced temporarily. If the temperature rises above 80 °C the device switches off automatically in order to prevent thermal overload.

2.8 Initial setup

The “Initial Setup” starts automatically when the inverter is switched on for the first time. This procedure only has to be completed when the device is commissioned for the first time. To start with, English text appears inviting you to select the required language. The subsequent setup messages will then appear in the selected language. Then select the country where the inverter is installed. Next, please check the date and time and make any necessary corrections. The date set here is stored as the commissioning data and can be retrieved via the “Information” menu. All settings (apart from the country setting) can be modified later via the “Settings” menu.

The initial setup is still concluded with the ✓ key.



Confirm the installation country with the ✓ key.

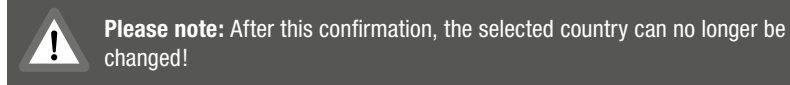

Exit this menu with the ✕ key. “Initial setup” will start again.

Important: The selected country must match the actual installation site of the inverter.

Correct setting of the country ensures that the inverter operates within country-specific limit values. If the selected country does not match the actual installation site the inverter will load incorrect limit values.

This may invalidate the ESC operating licence for the inverter.

2.9 Status signalling contact

The status signalling contact is used for remote monitoring. The potential-free relay contact enables the status of the inverter to be monitored. The contact is located at the front of the unit between the DC and AC ports.

The functionality of the status signalling contact can be set in the Settings menu as follows:

Setting	Function
Off	The status signalling contacts are deactivated (remain in inactive state).
Mains	In mains mode the NO status signalling contact closes immediately and is opened again with the set delay as soon as the device is no longer in feed mode.
Error	The NO status signalling contact closes after the set delay time if a malfunction, fault or alarm occurs during this time. The relay opens immediately when the fault is no longer present.

The electronic monitoring system is supplied from the solar generator, i.e. the status signalling contact is open during the night and when the DC side is switched off.

The events that may trigger the status signalling contact are listed in Section 4.6 Status messages.



A suitable mating connector for connecting the status signalling contact can be ordered via the SolarMax hotline.

Status signalling contact

Pin assignment:

Pin	Contact:
1	NO
2	COM
3	NC

Technical data of the status signalling contacts

U max	I max
250 VAc	1 A
30 Vdc	1 A

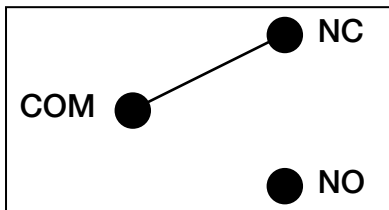

Inactive state

3. Auto Test

The Auto Test function is required according to the Italian DK 5940 standard. It enables verification of the voltage and frequency monitoring function. The Auto Test option is only available in the main menu if "Italy" was selected as the installation location.

The Auto Test functionality and procedure is described below.

3.1 Auto Test definition according to DK 5940 (Italy)

During the Auto Test procedure in mains mode the trigger threshold for AC voltage and frequency monitoring is varied linearly with a ramp of $\leq 0.05\text{Hz/s}$ and $\leq 0.05\text{ Vn/s}$ ($V_n = 230\text{ Vac}$). At some point during the test the threshold will coincide with the current measured value, leading to triggering of the monitoring intervention. After each test step the values of the trigger thresholds, delay times, current measured frequency and AC voltage values, and the standard threshold trigger value are displayed.

3.2 Start Auto Test

To start the Auto Test the inverter must be installed as described in Section 2. The Auto Test can be activated only if there is sufficient irradiance and the inverter is connected to the mains and is in feed mode.

1. Wait until the inverter has connected itself to the mains.
2. Select Auto Test in the main menu.
3. Answer the question whether the Auto Test should be executed with YES.

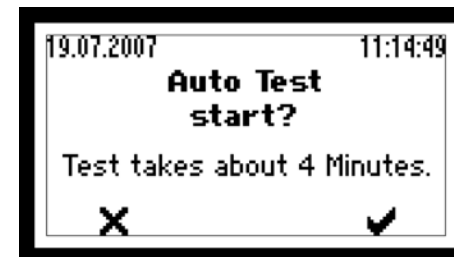

4. The Auto Test now runs automatically.

PLEASE NOTE: if a fault occurs during the tests or the irradiance is too low the Auto Test is aborted and the message “Auto Test aborted” appears in the display together with an associated error message.



3.3 Procedure

Maximum voltage

1. The set voltage monitoring threshold Vac max is displayed.
2. The threshold value is decremented linearly until it reaches the current mains voltage value and mains monitoring is triggered.
3. The trigger value, the delay time, the current value and the default voltage monitoring value (Vac max) are displayed.

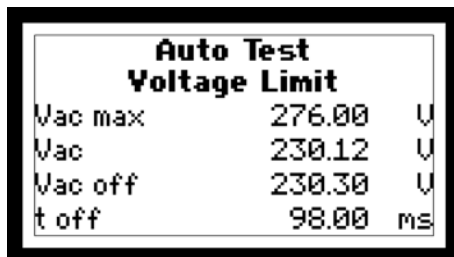

Minimum voltage

1. The set voltage monitoring threshold Vac min is displayed.
2. The threshold value is incremented linearly until it reaches the current mains voltage value and mains monitoring is triggered.

3. The trigger value, the delay time, the current value and the default voltage monitoring value (Vac min) are displayed.

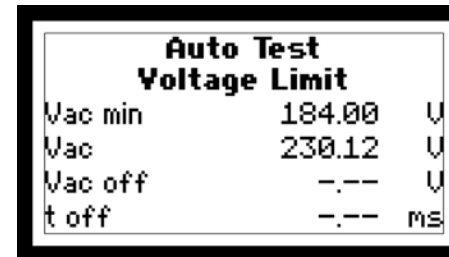

Maximum frequency

1. The set frequency monitoring threshold f max is displayed.
2. The threshold value is decremented linearly until it reaches the current mains frequency value and mains monitoring is triggered.
3. The trigger value, the delay time, the current value and the default frequency monitoring value (f max) are displayed.

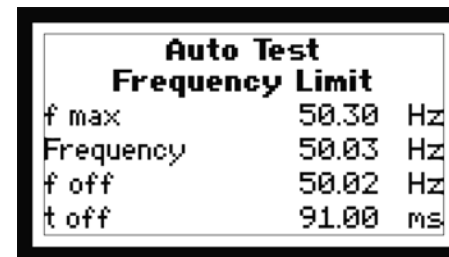

Minimum frequency

1. The set frequency monitoring threshold f min is displayed.
2. The threshold value is incremented linearly until it reaches the current mains frequency value and mains monitoring is triggered.
3. The trigger value, the delay time, the current value and the default frequency monitoring value (f min) are displayed.

After the Auto Test is complete the inverter returns to normal operation.

4 Operation and fault display

4.1 Graphics display

The graphics display at the front is used to display system parameters, status information, and SolarMax fault messages, thereby offering the user convenient options for obtaining information about the device status.

The graphics display is backlit in order to improve readability under adverse light conditions. The backlight switches on whenever one of the three keys is pressed, and remains on for 180 seconds after the last key activity.







4.2 LED display

In addition to the graphics display, an LED display is available for indicating the device status (green, red or orange).

LED display	Device status	Description
Off	Offline	Device is switched off
Flashing (green)	Startup	Device starting (initialisation, restart delay)
Green	Mains operation	Device feeding in
Orange	Malfunction	Malfunction (e.g. mains monitoring, overtemperature)
Flashing (red)	Error	Device fault
Green/red flashing	Alarm	Alarm messages see Section 4.7

4.3 Menu key symbols

Seven symbols are used for menu prompting:

Symbol	Function / description
	Scrolling upwards / increment number, or next element
	scroll down or previous element
	Back to higher-level menu
	Select next number
	Shows the required submenu or stores any changes
	Starts edit mode for the selection
	Cancel

4.4 Menu structure

The following submenus can be called up from the main menu:

- Overview
- Measured Values
- Statistics
 - Days
 - Months
 - Years
 - Total
 - Reset
- Configuration
- Settings
 - Language
 - Time
 - Date
 - Device address
 - Ethernet
 - IP address
 - Netmask
 - TCP Port
- Auto Test*
- Information

*Auto Test if regional setting is set to "Italy" (see Section 3)

Use the arrow keys **↑** and **↓** to select the required menu. Use the **✓** key to switch to the selected menu.

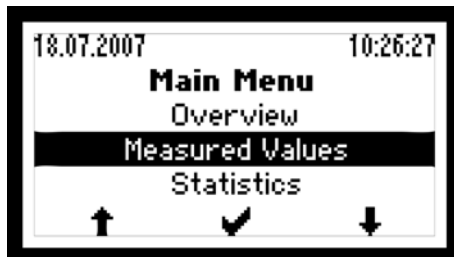

Overview

If none of the three keys are pressed within 120 seconds, the display will automatically change to the overview menu, in which the three main measured values and the operating status are shown.

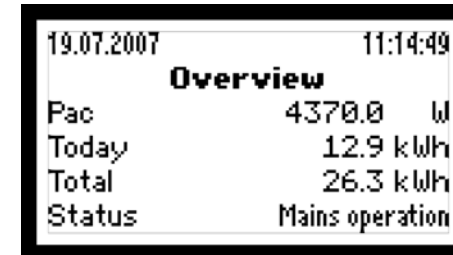

- ➔ current inverter output
- ➔ yield today
- ➔ total yield since commissioning
- ➔ operating status

Measured Values

The following measurement readings can be displayed:

- Vdc ➔ current solar generator voltage
- Idc ➔ current solar generator current
- Vac ➔ current mains voltage
- Iac ➔ current infeed current
- Pac ➔ current inverter output
- Frequency ➔ mains frequency
- Temperature ➔ heat sink temperature
- Fan (on/off) ➔ fan switched on or off

A maximum of four measured values can be displayed simultaneously. Use the arrow keys **↑** and **↓** to switch to other values. Use the **←** key to switch back to the main menu.

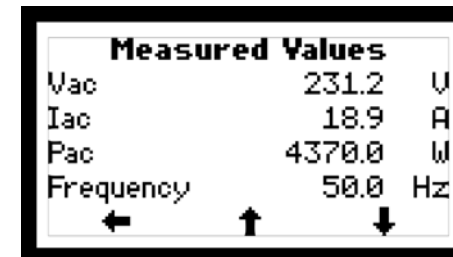

Statistics

The following statistics can be displayed:

- Days
- Months
- Years
- Total
- Reset

Use the arrow key \downarrow to select the required menu. Use the \checkmark key to switch to the selected menu. Use the \leftarrow key to switch back to the main menu.



Use the arrow keys \uparrow and \downarrow to display the yields for the last 31 days. Use the \leftarrow key to switch back to the Statistics menu.

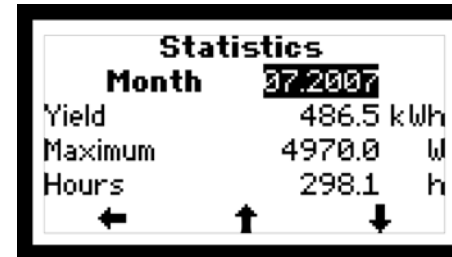

- \rightarrow monthly yield
- \rightarrow maximum power fed to the grid
- \rightarrow operating hours

Use the arrow keys \uparrow and \downarrow to display the yields for the last 12 months. Use the \leftarrow key to switch back to the Statistics menu.



- \rightarrow annual yield
- \rightarrow maximum power fed to the grid
- \rightarrow operating hours

Use the arrow keys \uparrow and \downarrow to show the yields for the last ten years. Use the \leftarrow key to switch back to the Statistics menu.

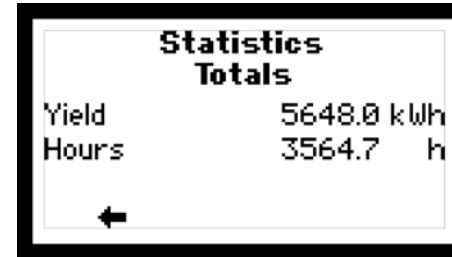

This screen shows the total yield and the operating hours of the inverter since it was commissioned. Use the \leftarrow key to switch back to the Statistics menu.



Use the ✓ key to confirm resetting of all statistics. Use the ✕ key to exit the menu without resetting the statistics.

Configuration

The following limit values and operating parameters cannot be modified via the graphics display, because they are part of the country-specific settings (see also section 2.6).

Country	The installation country set during commissioning is displayed here
Vac min	Minimum permissible mains voltage
Vac max	Maximum permissible mains voltage
Vac 10min max	Maximum permissible mean value of the mains voltage over the last 10 minutes
Iac max	Maximum mains current
Ierr max	Maximum permissible fault current (rms value) on the DC side
Iac mean max	Maximum permissible DC component of fed-in mains current
Pac max	Maximum AC output that can be fed in
f max	Maximum permissible mains frequency
f min	Minimum permissible mains frequency
Restart delay	Grid feeding delay after disconnection from the mains
df/dt max	Maximum permissible mains frequency variation per second

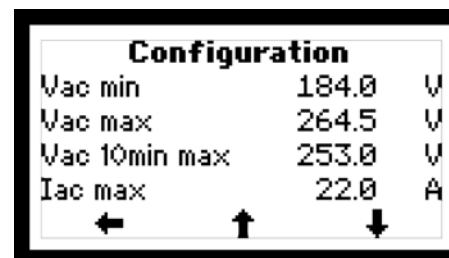

Use the arrow keys ↑ and ↓ to display any value. Use the ← key to switch back to the main menu.

Settings

The following settings can be implemented via the graphics display:

Language	Language selection: German, English, French, Italian or Spanish
Time	Internal clock setting
Date	Current date setting
Device address	Enter a device address between 1 and 249. If several inverters are connected to form a network, each device must have a different address
Ethernet	Switches the Ethernet interface on or off
IP address	Ethernet interface configuration (see section 6)
Netmask	Ethernet interface configuration (see section 6)
TCP port	Ethernet interface configuration (see section 6)
Status relay	Defines the function of the status signalling contact (see Section 2.9)
Status relay delay	Delay time setting for the status signalling contact

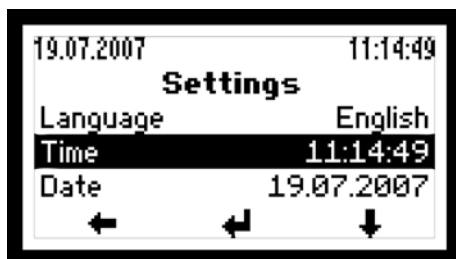

Use the arrow key ↓ to select the required parameter. Use the ↵ key to switch to edit mode for the selected parameter. Use the ← key to switch back to the main menu.



In edit mode each digit is modified individually. Example: use the ↑ key to increment the selected digit. Once the right value has been selected use the → key to switch to the next digit and increment it with the ↑ key. Once all digits have been set, exit edit mode with the ✓ key.

Information

This menu shows the following information:

- Device type (SM2000S, SM3000S, SM4200S, SM6000S)
- Firmware version
- Date of commissioning
- Web address (www.solarmax.com)



Use the ← key to switch back to the main menu.

4.5 Communication activity

If the symbol in the top line of the display is lit the inverter has received data.

Symbol	Mode	Function / description
		No communication (no symbol is displayed)
Ⓢ	Comm	Communication activity; this is displayed if the inverter has received data
ⓔ	Ethernet	Ethernet is displayed if Ethernet mode is activated

4.6 Status messages

The following table shows the possible status messages, subdivided into four categories:

	Status message	Cause
Startup LED: Flashing (green)	Irradiance too low	There is too little solar radiation and infeed is not possible.
	Startup...	In this mode, the inverter checks all the conditions which must be fulfilled to ensure secure infeed.
	Restart in...s	After a shutdown this value indicates the number of seconds after which feed mode will resume.
Mains operation LED: Green	MPP operation	The inverter has found the operating point of the solar generator with the maximum inverter output.
	Maximum power	The inverter limits the output to the maximum power of the device. This may happen if the solar generator is oversized.
	Mains operation	The inverter is connected to the mains and is operating in feed mode.
	Idc limitation	The inverter limits the solar generator current to the maximum permissible value. This may occur if the solar generator is designed such that the current at MPP exceeds the maximum permissible input current of the inverter.
	Iac limitation	The inverter limits the mains current to the maximum permissible value. This can happen when there are strong fluctuations in irradiance or with an oversized solar generator.

	Status message	Cause
LED: Orange	Vdc too high	The solar generator voltage is too high.
	Iac asymmetric	The DC component of the mains current is too high.
	Ierr too high	A fault current in excess of the permissible limit value has occurred on the solar generator side.
	No mains	No mains voltage.
	Frequency too high	The mains frequency is too high.
	Frequency too low	The mains frequency is too low.
	Mains error	A mains fault was detected.
	Bad mains quality	The 10-minute mean value of the mains voltage exceeds the permissible limit value (according to VDE0126-1-1).
	Vac too high	The mains voltage is too high.
	Vac too low	The mains voltage is too low.
	Temp. too high	The inverter has interrupted the feed mode because the heat sink temperature exceeds 80 °C (see also section 2.7).
LED: Flashing (red)	Insulation fault	An insulation fault was detected in the solar generator or in the wiring of the solar generator.
	Device error	An internal inverter fault has occurred.
	Overvoltage	The DC link voltage of the inverter is too high.
	Overcurrent	An overcurrent has occurred in the inverter.

4.7 Alarm signals

The alarm messages are displayed in the graphics alternately with the status message. An alarm does not cause a shut-down, although a loss of yield should be expected. The LED display flashes alternately red and green if an alarm is pending. As long as the inverter does not operate in mains mode the alarm message is only displayed in the graphics display. In this case the LED display indicates the current device status.

The following table shows the possible alarm messages:

	Alarm message	Cause
Alarm LED: green/red flashing	Temp. limitation	The inverter output is reduced when the heat sink temperature reaches 75 °C (see also Section 2.7).
	Failure fan 1	A failure of the external fan has been detected.
	Failure fan 2	A failure of the internal fan has been detected.
	Failure temp. sensor	A failure of the temperature sensor has been detected.

5 Troubleshooting

5.1 Introduction

Sputnik Engineering only supplies SolarMax inverters that have passed our extensive tests. Furthermore, for each device a long-term test under full-load conditions is carried out over several hours.

In the unlikely event of your PV system being affected by a fault we recommend the following procedure:

1. Ensure that the solar generator is correctly installed and connected to the mains. Check the connections and the procedure described in Section 2 (Installation).
2. The integrated graphics display facilitates troubleshooting. Further details are provided in the following subsection.
3. Contact our SolarMax hotline if you are unable to rectify the fault with the suggested measures.

SolarMax-Hotline

Calling from Germany:	0180 / 276 5 276
Calling from Austria:	0049 / 180 276 5 276
Calling from Switzerland:	032 / 346 56 06
Calling from France:	0033 / 178 424 042
Calling from Spain:	0034 / 902 160 626
Calling from Italy:	0039 / 0362 312 279
Calling from other countries:	0041 / 32 346 56 06
Fax Hotline:	0041 / 32 346 56 26
E-mail:	hotline@solarmax.com



5.2 Troubleshooting via the graphics display

Fault: No graphics display	
Possible cause	Remedy
DC insulation switch switched off	Switch on the DC insulation switch.
Irradiance too low	Wait until irradiance is high enough.
Internal fault	Notify SolarMax hotline.
Strings interrupted	Rectify interruption.

Malfunction: Graphics display flashes periodically, or Status message: Irradiance too low	
Possible cause	Remedy
Irradiance too low	Wait until irradiance is high enough.

Malfunction: Overtemperature	
Possible cause	Remedy
Ambient temperature too high	Ensure air can circulate at the side of the cooling fans.
Insufficient air circulation	
Fan blocked	Clean / replace fan (see Section 5.3).

Malfunction: Iac asymmetric	
Possible cause	Remedy
DC component of the mains current is too large	First switch off AC side and then DC side for 20 seconds, then switch on again. For recurring faults contact the SolarMax hotline.

Malfunction: Ierr too high	
Possible cause	Remedy
Fault current too large as level-change or absolute value	Check solar generator and DC cabling.
Earth leakage or insulation fault on the DC side	

Malfunction: Insulation fault	
Possible cause	Remedy
Earth leakage or insulation fault on the DC side	Check solar generator and DC cabling.
Phase and neutral conductor interchanged	Swap phase and neutral conductor in the AC coupling connector.

Malfunction: No mains, frequency too high or too low	
Possible cause	Remedy
No grid or mains voltage interruption	Check AC connection.
Mains frequency outside the tolerance	Wait until the mains frequency is within tolerance.

Malfunction: Mains fault	
Possible cause	Remedy
Stand-alone operation was detected	For recurring faults contact the SolarMax hotline.

Malfunction: Vac too low or Vac too high	
Possible cause	Remedy
Mains voltage too low / too high	Check mains voltage.

Malfunction: Vdc too high	
Possible cause	Remedy
The solar generator voltage exceeds the permissible value (see Technical data)	Immediately disconnect the DC insulation switch. Check module configuration.

Alarm: Failure fan 1	
Possible cause	Remedy
External fan faulty	For recurring faults contact the SolarMax hotline (a faulty fan leads to power reduction or even total shut-down).

Alarm: Failure fan 2	
Possible cause	Remedy
Internal fan faulty	For recurring faults contact the SolarMax hotline (a faulty fan leads to power reduction or even total shut-down).

Alarm: Failure temp. sensor	
Possible cause	Remedy
Internal temperature too high or temperature sensor faulty	For recurring faults contact the SolarMax hotline.

Alarm: Temp. limitation	
Possible cause	Remedy
Internal temperature too high: device reduces output. Check function of the external fan; check and clean the fan grille	For recurring faults contact the SolarMax hotline.

Fault: Device error	
Possible cause	Remedy
Internal fault	For recurring faults contact the SolarMax hotline.

The following faults can only be displayed during the inverter initialisation phase and indicate a device fault:

Error message	Remedy
SUPPLY FAILURE	For recurring faults contact the SolarMax hotline.
ADC REFERENCE ERROR	
EEPROM ERROR	
CONFIGURATION ERROR	Wait until irradiance is high enough.
IRRADIANCE TOO LOW	

5.3 Maintenance

The SolarMax inverters generally operate maintenance-free. However, we recommend checking the AC output in the LC display during strong irradiance at regular intervals.

The cumulative operating and kilowatt hours provide additional information about the performance of your PV system.

A faulty external fan can be replaced without having to open the device: simply release the four fastening screws of the fan and open the cable plug.

Before changing the external fan disconnect the DC circuit breaker and the AC side!

6 Data communication

Sputnik Engineering offers the MaxComm communication platform for solar systems with SolarMax inverters. It offers a wide range of options for data recording and monitoring of your PV system. The following pages provide an overview of current products. Detailed information and product news can be found on our website at www.solarmax.com.

MaxTalk: for occasional communication or service technicians

The MaxTalk PC software is ideal for occasional inverter data queries or device settings. MaxTalk can be downloaded free of charge from our website.

MaxVisio: for smaller PV systems without remote monitoring

MaxVisio is the ideal stand-alone display for smaller PV systems without remote monitoring. MaxVisio displays and records the data for the whole system and for the individual devices. MaxVisio is operated via a convenient touchscreen display.

MaxWeb: the gateway to Internet e-based communication

MaxWeb is a data logger, monitoring unit and web server in one. MaxWeb is the ideal solution for reliable and professional monitoring of your SolarMax PV installation. You can access your installation directly via an Internet connection in order to check current measured values or change your device settings. The data logger records operating parameters, yield values and events and automatically transfers them to the SolarMax web portal. In the event of a fault, MaxWeb sends alarm signals via e-mail or SMS.

SolarMax web portal: system data can be recalled at any time

The SolarMax web portal is the ideal complement to the MaxWeb data logger. The SolarMax web portal offers access to the data of your PV system from any Internet access point. The SolarMax web portal offers a wide range of graphical and tabular data analysis options for your PV system.

Other accessories	
Product	Function
MaxMeteo	Logging of solar radiation and cell temperature
MaxCount	Logging of ESC meter readings
MaxConnect plus	Connection box with string monitoring
MaxDisplay	Control of large displays

To use the communication interface(s), enter the following parameters in the “Settings” menu:

Device address

If several inverters are connected to form a network (RS485), each device must have a different address. Addresses between 1 and 249 can be used. Please note that each device in the network must have a different address.

Ethernet (on / off)

To use the right-hand communication socket as Ethernet interface, enter “on”.

IP address

To access your inverter from the local network (LAN), enter a free IP address from your LAN network.

Netmask

Enter the associated subnet mask for your IP address.

TCP Port

Enter the required TCP port for communication with the inverter. Please note that the TCP port must be greater than 1023, because this range is reserved for predefined applications (Well Known Services).

Further information on data communication can be found in the download area at www.solarmax.com.

7 Disposal

At the end of its service life please dispose of the inverter according to the relevant disposal regulations applicable for the installation location. Alternatively you may return the inverter to Sputnik Engineering for proper disposal (the address can be found in the Introduction section). Please note that there is a charge for this service.

8 Technical description

8.1 Technical configuration SolarMax 2000S/3000S

The DC voltage of the solar generator is transferred to a DC bus voltage via a low-loss step-up converter. The IGBT bridge circuit generates the sinusoidal infeed current.

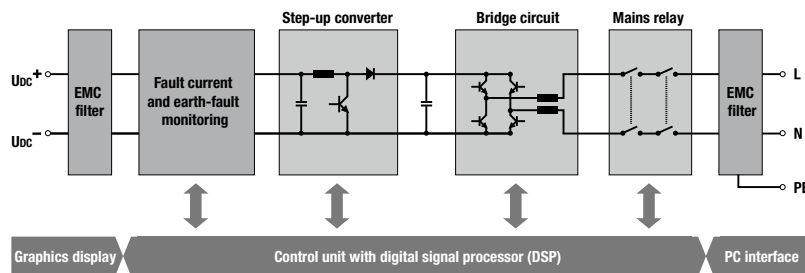

Block diagram SolarMax 2000S/3000S

8.2 Technical configuration SolarMax 4200S/6000S

The DC voltage of the solar generator is transferred to a DC bus voltage via a low-loss step-up converter. The IGBT bridge circuit generates the sinusoidal infeed current.

The innovative MaxShare concept used in the SolarMax 6000C for the first time leads to a significant increase in efficiency in the partial load range. MaxShare switches the required power stages on or off according to the current output:

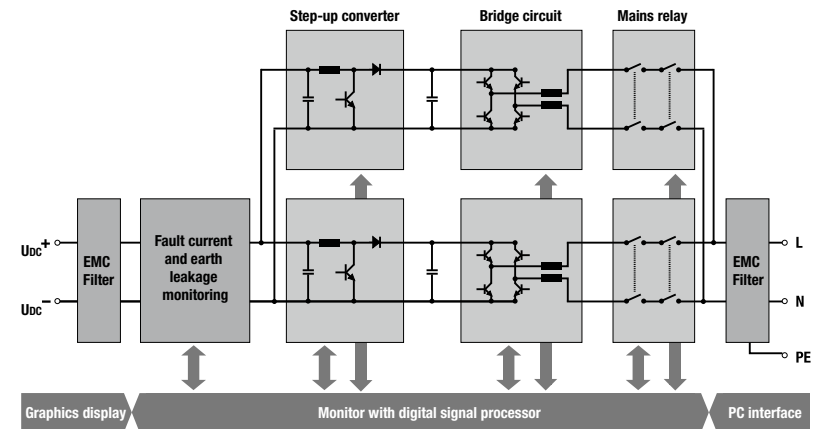

Block diagram SolarMax 4200S/6000S

8.3 Safety functions

In order to ensure a high safety standard, SolarMax inverters feature integrated fault current monitoring on the DC side.

In the event of an earth fault current, the fault current monitoring system detects the differential current and interrupts the mains operation. In the event of accidental contact, the fault current monitoring system triggers a safety mechanism that switches the device off, thereby preventing electric shock.

8.4 Control functions

SolarMax features state-of-the-art measuring and control electronics. A digital signal processor (DSP) generates the PWM signals and offers the following inverter control functions:

- Automatic on/off-switching
- Grid monitoring (overvoltage, undervoltage, mains frequency, detection of stand-alone operation)
- Mains synchronisation and sinusoidal current control
- Maximum power point tracking (MPPT, searching for the optimum operating point)
- Output limitation for oversized solar generators
- Input and output current limitation
- Monitoring of the power electronics
- Monitoring of the heat sink temperature
- Control of the graphics display
- External communication via RS485 and/or Ethernet

8.5 Technical data SolarMax 2000S/3000S

	SolarMax 2000S	SolarMax 3000S
Input side (DC)		
Maximum generator output *)	2300 W _{STC}	3300 W _{STC}
MPP-Range	100...550 V _{DC}	
Maximum input voltage	600 V _{DC}	
Input current	0...11 A _{DC}	0...11 A _{DC}

Output side (AC)		
Rated output	1800 W	2500 W
Maximum output	1980 VA	2750 VA
Nominal mains voltage / range	230 V _{AC} / 184...300 V _{AC}	
Power factor (PF)	> 0.98	
Nominal mains frequency/range	50 Hz / 45...55 Hz	
Harmonic distortion at rated output	< 3 %	

System data		
Maximum efficiency	97 %	97 %
European efficiency	95.4 % @ 400 V _{DC} 94.6 % @ 300 V _{DC}	95.5 % @ 400 V _{DC} 94.9 % @ 300 V _{DC}
Ambient temperature	-20 °C...+ 60 °C	
Rated output up to ambient temperature of	+ 45 °C	
Relative humidity	0...98 %, no condensation	
Protection type	IP54	
Circuit type	digital sine wave controller, transformerless, two-stage (no galvanic isolation)	
Heat dissipation	convection / fan (fan exchangeable from outside)	
Display	graphic LC display 128 x 64 pixels, with background illumination and status LED	
Operation	three push buttons	
DC insulation switch	integrated DC insulation switch according to VDE 0100-712	
CE-compliant according to	EN 50178, EN 61000-6-2, EN 61000-6-3, EN 61000-3-2, EN 61000-3-3	
Mains monitoring	VDE 0126-1-1	
Fault current monitoring	VDE 0126-1-1	
Mark of conformity	"Type approved" TÜV Rheinland, "GS certified safety"	
Data logger	data logger for energy yield, peak output and operating duration for the last 31 days, 12 months and 10 years	
Data communication	RS 485 / Ethernet	
Fault alarm contact	M12 connector with relay as N/C contact / N/O contact	
Dimensions (WxHxD)	545 x 290 x 185 mm	
Weight	13 kg	13 kg
Casing	aluminium, cover powder-coated	

*) Recommended overdimensioning 15 % (ISE Fraunhofer study)
All rights, amendments and errors reserved.

8.6 Technical data SolarMax 4200S/6000S

	SolarMax 4200S	SolarMax 6000S
Input side (DC)		
Maximum generator output *)	5000 W _{STC}	6000 W _{STC}
MPP-Range	100...550 V _{DC}	
Maximum input voltage	600 V _{DC}	
Input current	0...22 A _{DC}	0...22 A _{DC}

Output side (AC)		
Rated output	3800 W	4600 W
Maximum output	4180 VA	5060 VA
Nominal mains voltage / range	230 V _{AC} / 184...300 V _{AC}	
Power factor (PF)	> 0.98	
Nominal mains frequency/range	50 Hz / 45...55 Hz	
Harmonic distortion at rated output	< 3 %	

System data		
Maximum efficiency	97 %	97 %
European efficiency	95.8 % @ 400 V _{DC} 95.1 % @ 300 V _{DC}	96.2 % @ 400 V _{DC} 95.5 % @ 300 V _{DC}
Ambient temperature	-20 °C...+ 60 °C	
Rated output up to ambient temperature of	+ 45 °C	
Relative humidity	0...98 %, no condensation	
Protection type	IP54	
Circuit type	digital sine wave controller, transformerless, two-stage (no galvanic isolation)	
Heat dissipation	convection / fan (fan exchangeable from outside)	
Display	graphic LC display 128 x 64 pixels, with background illumination and status LED	
Operation	three push buttons	
DC insulation switch	integrated DC insulation switch according to VDE 0100-712	
CE-compliant according to	EN 50178, EN 61000-6-2, EN 61000-6-3, EN 61000-3-12, EN 61000-3-11	
Mains monitoring	VDE 0126-1-1	
Fault current monitoring	VDE 0126-1-1	
Mark of conformity	"Type approved" TÜV Rheinland, "GS certified safety"	
Data logger	data logger for energy yield, peak output and operating duration for the last 31 days, 12 months and 10 years	
Data communication	RS 485 / Ethernet	
Fault alarm contact	M12 connector with relay as N/C contact / N/O contact	
Dimensions (WxHxD)	545 x 290 x 185 mm	
Weight	15 kg	15 kg
Casing	aluminium, cover powder-coated	

*) Recommended overdimensioning 15 % (ISE Fraunhofer study)
All rights, amendments and errors reserved.

8.7 Glossary

Symbol	Meaning
Frequency	Mains frequency
f max	Maximum permissible mains frequency
f min	Minimum permissible mains frequency
df/dt max	Maximum permissible mains frequency variation per second
I _{ac}	Output current, mains current
I _{ac} max	Maximum permissible mains current
I _{ac} mean	DC component of mains current (mains symmetry)
I _{ac} mean max	Maximum permissible DC component of fed-in mains current
I _{err}	Fault current, stray module current
I _{err} max	Maximum permissible fault current (rms value) on the DC side
Restart delay	Restart delay after a shutdown
P _{ac}	Output
P _{ac} max	Maximum output
P _{dc}	Input power, generator output
V _{ac}	Output voltage, mains voltage
V _{ac} 10min	Mean value of the mains voltage over the last 10 minutes
V _{ac} 10min max	Maximum permissible mean value of the mains voltage over the last 10 minutes
V _{ac} max	Maximum permissible mains voltage
V _{ac} min	Minimum permissible mains voltage
V _{dc}	Input voltage, generator voltage

8.8 Efficiency

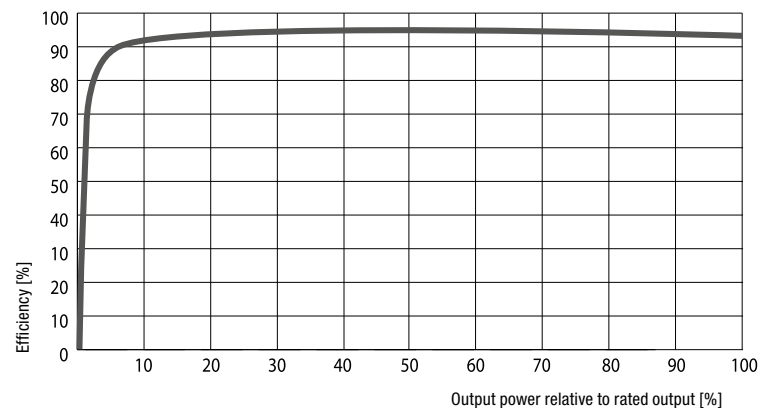

Efficiency SolarMax 2000S

P _{AC} [W]	P _{relativ} [%]	η _(250 VDC) [%]	η _(300 VDC) [%]	η _(400 VDC) [%]
90	5	85.2	85.8	87.1
180	10	89.8	90.2	93.2
360	20	93.2	93.5	94.8
540	30	94.6	94.7	95.6
900	50	95.4	95.6	96.1
1800	100	95.2	95.4	96.0
European efficiency		94.4	94.6	95.4

Efficiency SolarMax 3000S

P _{AC} [W]	P _{relativ} [%]	η _(250 VDC) [%]	η _(300 VDC) [%]	η _(400 VDC) [%]
125	5	87.0	87.5	89.7
250	10	91.5	91.8	93.6
500	20	94.2	94.5	95.5
750	30	94.9	95.3	95.6
1250	50	95.2	95.6	96.1
2500	100	94.4	95.1	95.5
European efficiency		94.4	94.9	95.5

Efficiency SolarMax 4200S

P_{AC} [W]	$P_{relativ}$ [%]	$\eta_{(250\text{ VDC})}$ [%]	$\eta_{(300\text{ VDC})}$ [%]	$\eta_{(400\text{ VDC})}$ [%]
190	5	90.8	91.0	92.8
380	10	93.6	93.8	94.5
760	20	94.6	95.1	95.8
1140	30	94.8	95.4	96.1
1900	50	95.0	95.5	96.2
3800	100	94.4	95.0	95.6
European efficiency		94.6	95.1	95.8

Efficiency SolarMax 6000S

P_{AC} [W]	$P_{relativ}$ [%]	$\eta_{(250\text{ VDC})}$ [%]	$\eta_{(300\text{ VDC})}$ [%]	$\eta_{(400\text{ VDC})}$ [%]
230	5	91.0	92.1	93.4
460	10	94.1	94.5	95.5
920	20	95.1	95.7	96.2
1380	30	95.2	95.8	96.4
2300	50	95.3	95.9	96.5
4600	100	94.5	95.2	96.1
European efficiency		94.9	95.5	96.2

Legend:

P_{AC}	output power [W]
$P_{relativ}$	ratio of output power and rated output [%]
$\eta_{(VDC)}$	efficiency at associated input voltage [%]

9 Warranty

(Status: 12.11.2007)

9.1 Guarantee

Sputnik Engineering AG (hereafter: Sputnik) guarantees full function and lack of defects of its technical devices at the moment of shipment respectively in cases of sale of devices to natural persons for private use within the EU at the moment of their delivery to the consumer.

This guarantee applies only in case of malfunctions/defects which have been discovered within *five years* (for SolarMax 2000S-6000S) after shipment respectively delivery. The original invoice respectively the delivery receipt serve as proof for the relevant point of time. In all cases of guarantee, Sputnik must be notified of the inconformity clearly and in writing within this deadline.

In guarantee cases, the malfunctioning/defective device will be repaired or replaced by Sputnik-service personnel within a reasonable time, in either case free of charge, unless this is impossible or disproportionate.

Replacement or repair shall be deemed to be *disproportionate* if it imposes costs on Sputnik which, in comparison with the alternative remedy, are unreasonable, taking into account:

- the value the goods would have if there were no lack of conformity,
- the significance of the lack of conformity, and
- whether the alternative remedy could be completed without significant inconvenience to the buyer.

“Free of charge”:

- The guarantee covers only the costs for labour and materials used by Sputnik to bring the devices back to full function either *in Sputnik's factory or on-site by Sputnik service personnel*. All other costs, especially shipping costs, travel and hotel expenses for on-site repairs by Sputnik-service personnel as well as costs of repairs by the buyer himself or other persons are not covered by the guarantee and go to the expense of the buyer or the distributor, unless otherwise specified in a written agreement.
- In case of sale of devices to natural persons for private use within the EU and Switzerland, shipping costs as well as travel and hotel expenses for on-site repairs by Sputnik service personnel are also covered by the guarantee. However, Sputnik covers only the shipping and travel expenses for the distance between Sputnik and the official Sputnik distributor from which the defective/malfunctioning device was bought. Furthermore, Sputnik will not cover shipping costs, travel and hotel expenses if the sales point of this official Sputnik distributor is located in overseas territories of the EU or outside of the EU / outside of Switzerland.

In any case, Sputnik's guarantee services are only free of charge if Sputnik has been contacted in advance and has agreed to the services to be provided.

In a guarantee case, the buyer may require an appropriate reduction of the price or have the contract rescinded:

- if the buyer is entitled to neither repair nor replacement, or
- if Sputnik has not completed the remedy within a reasonable time, or
- if Sputnik has not completed the remedy without significant inconvenience to the buyer.

The buyer is not entitled to have the contract rescinded if the lack of conformity is minor.

Especially in the following cases, this guarantee does not apply and any liability on the part of Sputnik is excluded:

- **unauthorised technical intrusions, modifications or repairs of the devices by the buyer himself;**
- **use of devices for purposes they are not intended for, incorrect or unreasonable manipulation, incorrect or unreasonable installation, especially if the installation is made by non-authorised electricians;**
- **influence of foreign substances/bodies or superior force (lightning strike, overvoltage, floods, etc.);**
- **transport damage and other damage, which has occurred after the point of time in which the risk has passed to the buyer, as well as damage caused by incorrect packaging by the buyer.**

This guarantee is compatible with the “*Directive 1999/44/EC of the European Parliament and of the Council of 25 May 1999 on certain aspects of the sale of consumer goods and associated guarantees*”. Any legal rights under applicable national legislation within the personal, objective or geographic scope of this directive are not affected.

9.2 Prolongation of Services

Extended services beyond the scope of this guarantee will be provided by Sputnik upon request, according to the terms of a separate agreement on the prolongation of services. The warranty can be extended within the five-year warranty period by means of a corresponding supplementary contract.

9.3 Limitation of Liability and Warranty

To the maximum extent legally possible, any further liability of and/or alternative claims of warranty/guarantee against Sputnik are excluded. For commercial users, compensatory claims for loss of gain are also excluded.

9.4 Applicable Law

Unless explicitly agreed upon otherwise in writing, and as far as not in conflict with compulsory law, the material provisions of the UN Convention on Contracts for the International Sale of Goods (CISG) apply.

9.5 Place of Jurisdiction

Unless explicitly agreed upon otherwise in writing, and as far as not in conflict with compulsory law, the exclusive place of jurisdiction for all conflicts with Sputnik based on contractual, non-contractual and/or other types of claims lies in Biel, Switzerland.

Certificate

Declaration of conformity



EU Declaration of Conformity

for the
SolarMax 2000S, 3000S, 4200S, 6000S

grid-connected solar inverters manufactured by

Sputnik Engineering AG Biel/Bienne, Switzerland

We herewith confirm that the devices listed above comply with the directives of the Council of the European Union, in particular EMC Directive 2004/108/EC and Low-Voltage Directive 2006/95/EC.

The device types listed above therefore carry the CE mark.

The devices comply with the following standards:

	SM2000S	SM3000S	SM4200S	SM6000S
EMC Emission				
EN 61000-6-3: 2001 + A11: 2004	X	X	X	X
EN 61000-6-4: 2001	X	X	X	X
EMC Immunity				
EN 61000-6-1: 2001	X	X	X	X
EN 61000-6-2: 2005	X	X	X	X
Utility Interference				
EN 61000-3-2: 2006	X	X		
EN 61000-3-12: 2005			X	X
EN 61000-3-3: 1995 + A1: 2001 + A2: 2005	X	X		
EN 61000-3-11: 2000			X	X
Equipment safety*				
EN 50178: 1997	X	X	X	X

* Compliance with the EN 50178 device safety standard is monitored by TÜV Rheinland. The above-named devices therefore bear the "TÜV Rheinland Product Safety" logo.



Biel/Bienne, the 07.04.2008

Sputnik Engineering AG

Ch. von Bergen *Ph. Müller*
Christoph von Bergen Philipp Müller



Länderspezifische Zertifikate und Konformitäten können im Downloadbereich unter www.solarmax.com eingesehen werden.

Country-specific certification and conformities can be found and downloaded at www.solarmax.com.

Les certificats et déclarations de conformité spécifiques à chaque pays peuvent être consultés dans la zone de téléchargement, à l'adresse www.solarmax.com.

Certificados y documentos de conformidad específicos del país pueden verse en la zona de descarga en www.solarmax.com.

I certificati e le dichiarazioni di conformità nazionali si possono consultare nella rubrica „Downloads“ del sito www.solarmax.com.

SolarMax-Hotline

Deutschland	0180 / 276 5 276
Schweiz / Svizzera / Suisse	032 / 346 56 06
France	0178 / 42 40 42
Italia	0362 / 31 22 79
España	90 216 06 26
Other countries	+41 / 32 346 56 06
Fax	+41 / 32 346 56 26
E-mail	hotline@solarmax.com



Mixed Sources
Product group from well-managed
forests and other controlled sources
www.fsc.org Cert no. SCS-COC-100256
© 1996 Forest Stewardship Council

